

MODEL 138LR LIGHT DUTY BELT DRIVEN LIVE ROLLER

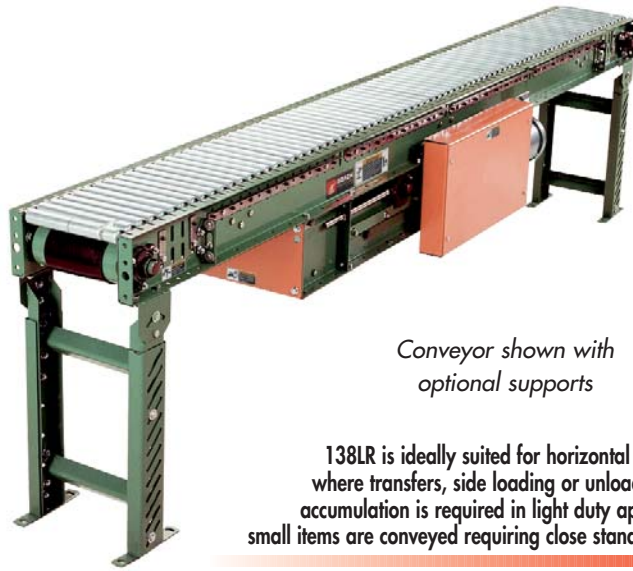

Conveyor shown with optional supports

138LR is ideally suited for horizontal conveying of items where transfers, side loading or unloading, or temporary accumulation is required in light duty applications or when small items are conveyed requiring close standard roller spacing.

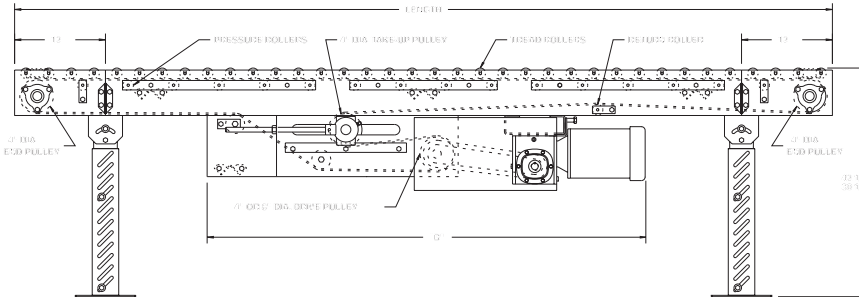
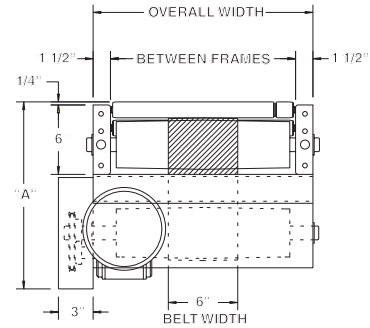

HP @ 60 FPM	"A" MAX		"B" MAX	
	4" DRV.	8" DRV.	4" DRV.	8" DRV.
1/3	15-5/8"	16-5/8"	58-5/32"	58-5/32"
1/2	15-5/8"	16-5/8"	58-5/32"	58-5/32"
3/4	16"	16-5/8"	58-25/32"	58-25/32"
1	16-1/4"	16-5/8"	59-17/32"	59-17/32"
1-1/2	17-1/8"	17-1/8"	61-21/32"	61-21/32"
2	18"	18"	62-21/32"	62-21/32"

SPECIFICATIONS

TREAD ROLLERS: 1-3/8" dia. x 18 ga. galvanized steel, model 138G with 5/16" hex.

PRESSURE ROLLERS: 1-3/8" dia. x 18 ga. galvanized steel, model 138G with 5/16" hex.

RETURN ROLLERS: 1-3/8" dia. x 18 ga. galvanized steel, model 138G with 5/16" hex, adjustable.

BELTING: 6" wide black PVC-120 COS.

CENTER DRIVE: Reversible drive w/ 24" integral belt take-up. Specify location.

DRIVE PULLEY: 4" dia. with 1-3/16" dia. shaft or 8" dia. with 1-7/16" dia. shaft; both crowned and fully lagged.

END PULLEY: 4" dia., crowned, with 1-3/16" dia. shaft.

SPEED: 60 FPM, constant.

BED: 6" x 1-1/2" x 12 ga. channel frame slotted for tread rollers to pop-out. When unit is installed at 7'-0" elevation or higher, rollers must be retained in conveyor frame. Specify desired elevation. Bed sections attached with couplings and floor supports.

SQUARING RODS: Adjustable rods on underside of bed allow frame to be squared for improved belt tracking and are standard on all units over 30'.

MOTOR DRIVE: 1/3 HP, 230/460/3, 60 cycle, ODP right angle gear motor.

BEARINGS: All pulley bearings are precision, heavy duty, lubricated, ball bearing units with cast iron housings.

ROLLER CHAIN: Drive pulley is driven by No. 50 chain for 1-1/2 HP or less and No. 60 chain on larger drives. Chain take-up provided on motor base.

ELECTRICAL CONTROLS: Optional.



WARNING

Pop-out rollers should be retained in frame if unit is elevated to 7'-0" and above.

■ 3 week shipment

SPECIFICATION TABLE

50'-0" lengths and under are equipped with 4" dia. drive pulley; over 50'-0" will have an 8" dia. drive pulley

CONVEYOR LENGTH			6'	10'	15'	20'	25'	30'	40'	50'	60'	70'	80'	90'	100'
BF	OAW	BELT	Unit weights (lbs.) with 1-1/2" roller centers (For other centers, deduct weights below)												
10"	13"	2-1/4"	385	484	609	739	864	990	1250	1504	1752	2022	2281	2541	2794
16"	19"	2-1/4"	447	575	735	886	1046	1202	1517	1832	2150	2463	2778	3093	3409
22"	25"	2-1/4"	504	656	846	1035	1225	1410	1790	2161	2537	2913	3290	3665	4047

Deduct the following weights (lbs.) for other than 1-1/2" centers

BF	ROLLER CENTERS	6'	10'	15'	20'	25'	30'	40'	50'	60'	70'	80'	90'	100'
10"	3"	-36	-60	-90	-120	-150	-180	-240	-300	-360	-420	-480	-540	-600
16"	3"	-54	-90	-135	-180	-225	-270	-360	-450	-540	-630	-720	-810	-900
22"	3"	-72	-120	-180	-240	-300	-360	-480	-600	-720	-840	-960	-1080	-1200
10"	4-1/2"	-48	-80	-120	-160	-200	-240	-320	-400	-480	-560	-640	-720	-800
16"	4-1/2"	-72	-120	-180	-240	-300	-360	-480	-600	-720	-840	-960	-1080	-1200
22"	4-1/2"	-96	-160	-240	-320	-400	-480	-640	-800	-960	-1120	-1280	-1440	-1600

OPTIONAL EQUIPMENT

BELTING: 6" wide black PVC-150; 12" wide PVC-120.

END DRIVE: Mounted underneath conveyor. Minimum possible height is 20" TOR for underneath mounted end drive. Belt take-up required for end drive (if substituting end drive for center drive).

SIDE MOUNTED END DRIVE: Provides overall conveyor height of 9".

AUXILIARY TAKE-UP: Provides 24" of belt take-up. Specify location. See Power Accessories.

FLOOR SUPPORTS: Supports, knee braces, casters and polytier supports available. See Conveyor Accessories.

CEILING HANGERS: 5/8" dia. threaded rod with hardware to attach rods to conveyor. Provides 6" clearance between ceiling and TOR (furnished in place of floor supports). See Conveyor Accessories.

MOTORS: Available through 3 HP in TEFC, explosion proof, dirty duty, brake motor, 115/230/1, 575/3, etc.

SPEED: Constant speed 3-120 FPM; DC variable speed; AC inverter variable speed. Other constant or variable speeds available. **NOTE: CAPACITY CHANGES WITH SPEED.**

GUARD RAILS: 1-3/4" x 1" formed channel (model GC), adjusts horizontally to 8" wider than roller and vertically to 6" above roller; formed steel fixed (model FSG in 2", 4" and 6" heights; fixed channel (model FC); 1-1/2" angle (model GA1-1/2). See Conveyor Accessories.

ELECTRICAL CONTROLS: Magnetic starter (one direction or reversible); One direction manual starter; Momentary start/stop push button station; Forward/reversing /stop push button station. Mounting and pre-wiring for units up to 12' long.



POP-OUT ROLLERS (some rollers raised for clarity)

